

# Washer extractor

## WH6-14 Clarus Vibe



Washer featuring exceptional savings and effortless use



### Priority on people

Certified ergonomic design with a human-centered approach for an outstanding user experience

- ClarusVibe microprocessor and 7" color TS control: intuitive, fully editable programs, multi-language, on-screen statistics, fully controlling the detergent pumps
- Very easy connection to Jetsave and Dosave with one cable for power supply and one for dosing signals
- Simple connection to all generic pumps
- Connection to up to 15 pumps



### Long-term savings

Innovative features designed for lowest possible water, energy and detergent consumption, to save money and time, and embrace a sustainable lifestyle

- Automatic Savings weighs the linen and adjusts the water level to the amount of linen, saving water and energy at less than full load
- Intelligent Dosing ensures that the precise amount of chemicals will be added automatically according to the weight of the load, saving chemicals
- Power Balance measures, corrects the unbalance and adjusts the G force in real time, maximizing the dewatering, saving money and time in the drying process



### Pure control

Monitoring of the status of the equipment and performance from anywhere, allowing to take action to improve the business

- Washers connectable to OnE Laundry, the personal assistant for hygiene validation, process management and revenue management



### Global Advanced Hygiene

Global Advanced Hygiene program package\* with proven log 6 reduction\*\* disinfection of textiles through the laundry process, fulfilling the criteria of all local approved standards

### Main options and accessories

- Front loaded detergent dispenser, positioned at ergonomic height for easy access, clear visibility; 6 color coded compartments make dosing easy and flexible with dedicated compartments for powder or liquid chemicals as well as bleach and softener; removable compartments ensure easy maintenance
- Integrated Savings is measuring the load in real time, ensuring optimization of the load and maximum productivity. IS provides also extended machine lifetime through the unique overload protection function, as machine will not start if overloaded; it will also reduce water and energy consumption at less than full load
- Connection to booking-/payment system or coin meter



Images shown are a representation of the product only and variations may occur.

\* Programs available in the standard library of all products, excluding products for specific segments where water temperature is not controllable.

\*\* Log 6 reduction equals to 99,9999% viral infectivity reduction. The efficacy of reduction of SARS-CoV-2 and other pathogens in the process is confirmed by RISE (The Research Institute of Sweden) on the basis of Electrolux Professional laboratory data.

Main specifications				WH6-14			
Rated capacity, filling factor 1:9	kg/lb			14/30			
Drum, volume	litre			130			
	diameter	ø mm		650			
Extraction		rpm		1113			
G-factor				450			
Standard heating alternatives	electricity	kW		13.0			
	steam			x			
	non-heated			x			
<b>Consumption data "ECO 60°C"</b>				EI		Steam***	
Total time	min	Full load, 14 kg	Half load**, 6.5 kg	Full load, 14 kg	Half load**, 6.5 kg	Full load, 14 kg	Half load**, 6.5 kg
Water consumption (cold+hot)	litre	60	54	60	54	60	54
Energy consumption (motor/heating/hot water)	kWh	86+5	42+4	91+0	46+0	91+0	46+0
Steam consumption	kg	0.30/1.75/0.25	0.30/0.9/0.2	0.30	0.30	3.0	1.65
Residual moisture	%	-	-	3.0	1.65	45	46
		45	46	45	46	45	46

\* Water temperature 15°C cold water and 65°C hot water.

\*\* Programs with AS.

\*\*\* Depending on steam pressure.

Electrical connections					
Heating alternative	Main voltage		Heating power kW	Total power kW	Recommended fuse A
	Hz	Hz			
Electric heated	220-240V 1/1N ~	50/60	4.8/13.0	5.2/13.4	25/63
	220-240V 3 ~	50/60	4.8/13.0	5.2/13.4	16/35
	380-415V 3N/3 ~	50/60	4.8/13.0	5.2/13.4	10/20
	440V 3 ~	50/60	13.0	13.4	20
	480V 3 ~	60	13.0	13.4	20
Steam or Non heated	208-240V 1/1N ~	50/60	*	1.2	10
	380-480V 1 - (**)	50/60	*	1.2	10

\* Total power and recommended fuse does not depend on the heating power in those cases.  
 \*\* Prepared for 3 ~.

Water and steam connection		WH6-14
Water valves	DN	20
Water pressure	kPa	200-600
Capacity at 300 kPa	l/min	20
Drain valve	ø mm	75
Draining capacity	l/min	170
Steam valve	DN	15
Steam pressure	kPa	300-600
Liquid detergent supplies		5

Floor requirements		
Frequency of the dynamic force	Hz	18.6
Floor load at max extraction	kN	3.1 ± 0.5

Sound levels		
Sound power/pressure level at extraction*	dB(A)	78/62
Sound power/pressure level at wash*	dB(A)	63/48

Heat emission		
% of installed power, max		5

Shipping data**		
Weight	net, kg	263
Shipping volume	m <sup>3</sup>	1.37

Accessories		
Steel base		x
Hose kits for water or steam		x
Fluff collector		x

Dimensions in mm		
A	Width	910
B	Depth	820
C	Height	1325
D1		430
D2		490
E		1340
F		1045
G		80
H		1245
I		380
J		300
K		1205
L		1125
M		360
N		100
O		305
P		340
Q		215

1	Display	7	Cold/Hot water or Re-used water with network pressure (option)
2	Door opening ø 395 mm	8	Re-used water from tank/pump or Liquid detergent supply
3	Detergent box	9	Drain
4	Cold/Hot water (Detergent box)	10	Liquid detergent supply
5	Cold water	11	Electrical connection
6	Hot water	12	Steam connection

Front and side panels in silver grey and dark blue (color samples can be ordered on part number 472998313).

\* Sound power levels measured according to ISO 60704.  
 \*\* Average data. Crated weight/shipping volume depends on configuration. Please contact logistics for exact measures.

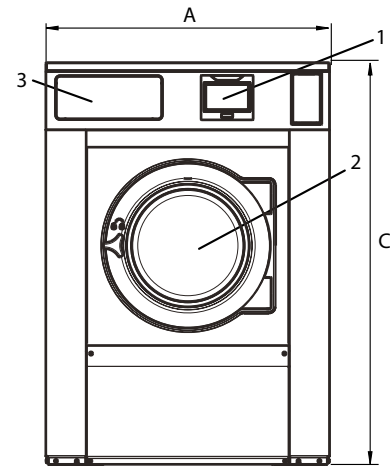

Front

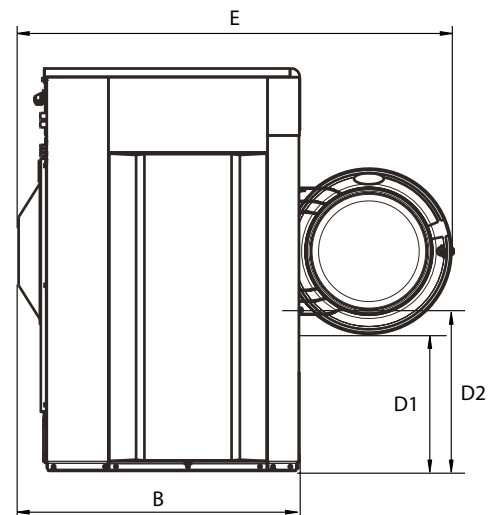

Side view

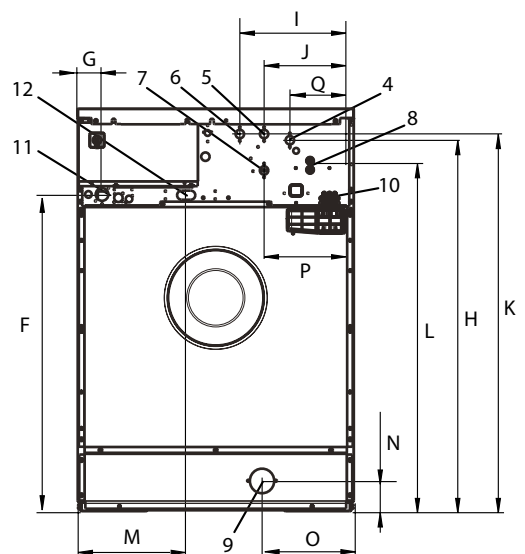

Rear